

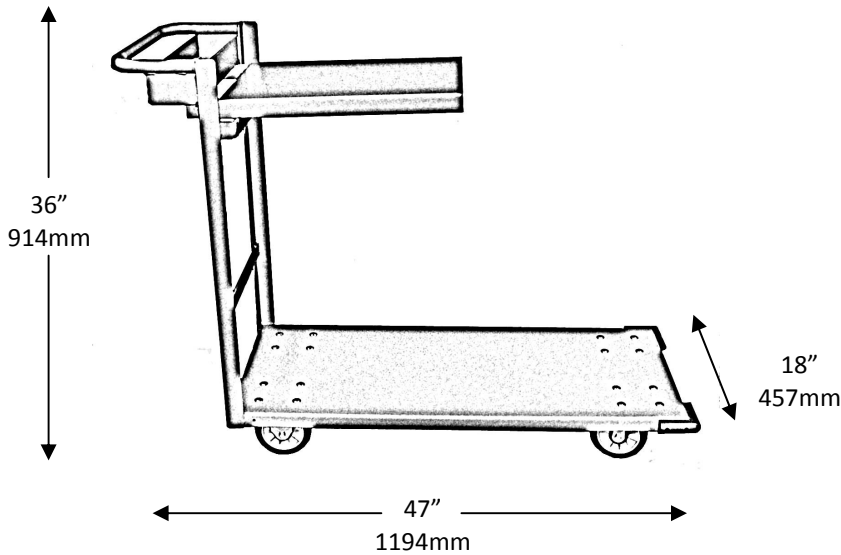

Model #908-5GRY

FINISH:
Grey Only

- FEATURES:**
- Retractable Upper Shelf
 - Convenient Upper Tray
 - 2 Swivel Casters w/ 5" Wheels
 - 2 Rigid Caster w/ 5" Wheels
 - 2 Corner Bumpers in Grey

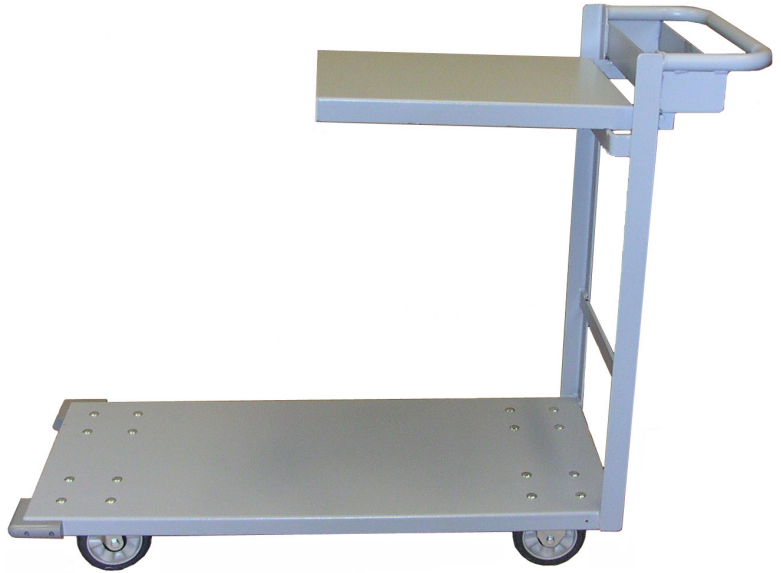

WEIGHT: 72 Lbs - 33 kg
LENGTH: 47" - 1194 mm
WIDTH: 18" - 457mm
HEIGHT: 36" - 914mm

JNE RETAIL EQUIPMENT INC.

Phone: 403-243-2705
www.jneretail.com

Fax: 403-243-1433
Email: sales@jneretail.com