

# Economy Checkout

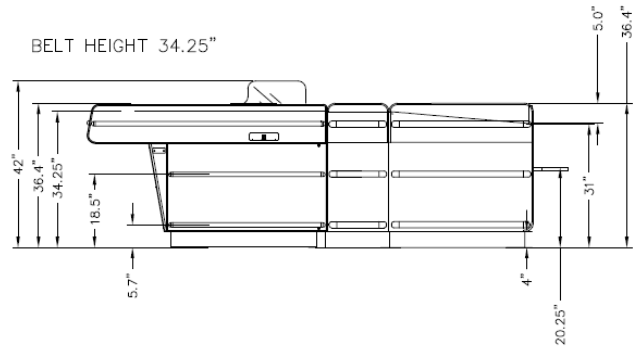

\*may not be exactly as shown



## Common Features

- All Steel Construction
- Welded Assemblies
- Powder Coat Paint Finish in a Neutral Beige
- 3 Rows of Black 1" Bumper for Cart Protection

## Scan and Pass / Scan and Bag

### 5' Left Front Conveyor

- Photo Electric Belt Control
- Hinged Product Divertor
- Cashier Lean Pad
- Scan Kit

### Cash Stand

- Mirror Panel
- ¼" Lexan Security Shield
- Utility Drawer

### Mid Bagging Module

- Single Bag Rack Unit
- Standard Bag Rack
- Straight Stainless Steel Chute

### 36" Rear Bagger

- Angled Sidewall
- Stainless Steel Pull-out shelf
- Cashier Side Fence

**JNE RETAIL EQUIPMENT INC.**

Ph: 403-243-2705  
www.jneretail.com

Fx: 403-243-1433  
sales@jneretail.com