



Shop & Roll Baskets



FEATURES:

- Polypropylene Molded Plastic
- Molded Plastic Handle
- Aluminum Telescopic Handle
- Solid Rubber Wheels
- Plated Steel Axles
- Stackable

OPTIONS:

- Full Colour-All Weather Vinyl Label w/ your Company Name or Logo

Choice of Red, Black or Green



Optional Basket Stand Also Available

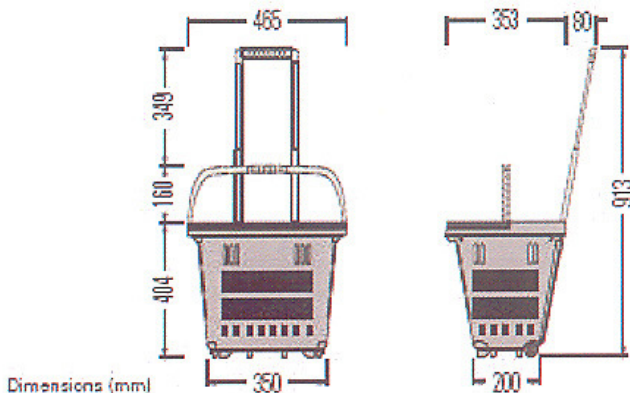

PAYLOAD CAPACITY: 2075 cu. In. - 34 litres

WEIGHT: 3 lbs - 1.44 kg

DEPTH: 14" - 353 mm

WIDTH: 18" - 465 mm

HEIGHT: 16" - 404 mm

JNE RETAIL EQUIPMENT INC.

Phone: 403-243-2705
www.jneretail.com

Fax: 403-243-1433
Email: sales@jneretail.com